

## Opti Max1000

### Fiber Deep Nodes



- **Improves bandwidth for advanced services**
- **Fiber deep node**
- **Innovative cost-effective design**
- **High output GaAs technology**
- **Compact size**
- **Optimizes fiber poor environments**
- **Serves commercial and residential applications**

C-COR introduces the Opti Max1000 Fiber Deep Node, a maximum value node for service providers who are launching HSD, VOD, PVR, and VoIP services. The Opti Max1000 offers the flexibility to function as a single output node in fiber-to-the-curb (FTTC) architectures with fewer downstream RF amplifiers and fiber-to-the-last-active (FTTLA) architectures as well as a parallel sub-node in existing HFC architectures.

The Opti Max1000 is the ideal solution for increasing bandwidth and revenues with limited capital expenditures. Incorporating the latest cutting edge GaAs technology, the Opti Max1000's high-output level at 870MHz enables greater reach, which saves approximately 1.2 actives per mile. Other features include optional 1310nm and 1550nm DFB transmitters and crowbar surge protection. These features combined with the Opti Max1000's high reliability translate to lower capital and operating expenses.

#### Features

- Segmentation improves bandwidth for advanced services
- Fiber deep node for economical deployment
- Innovative cost-effective design lowers capital and operational expenses
- High output reduces the number of actives per mile
- Compact size offers more than 30% volume savings over alternative offerings
- Optimizes fiber poor applications
- Feedback control stabilizes output power over temperature (patent pending)

## Applications

The Opti Max1000 is the ideal solution for relieving overloaded RF cascades, increasing return bandwidth capability, expanding systems with limited fiber count, and designing new builds with minimal fiber.

## Segmentation

When a large subscriber base leads to a bottleneck, there are two choices: A large segmentable node, or selectively redirecting overloaded RF cascades through the Opti Max1000. Segmentation options include co-locating an Opti Max1000 with an existing node, replacing an existing network amplifier, or replacing an existing network line extender.

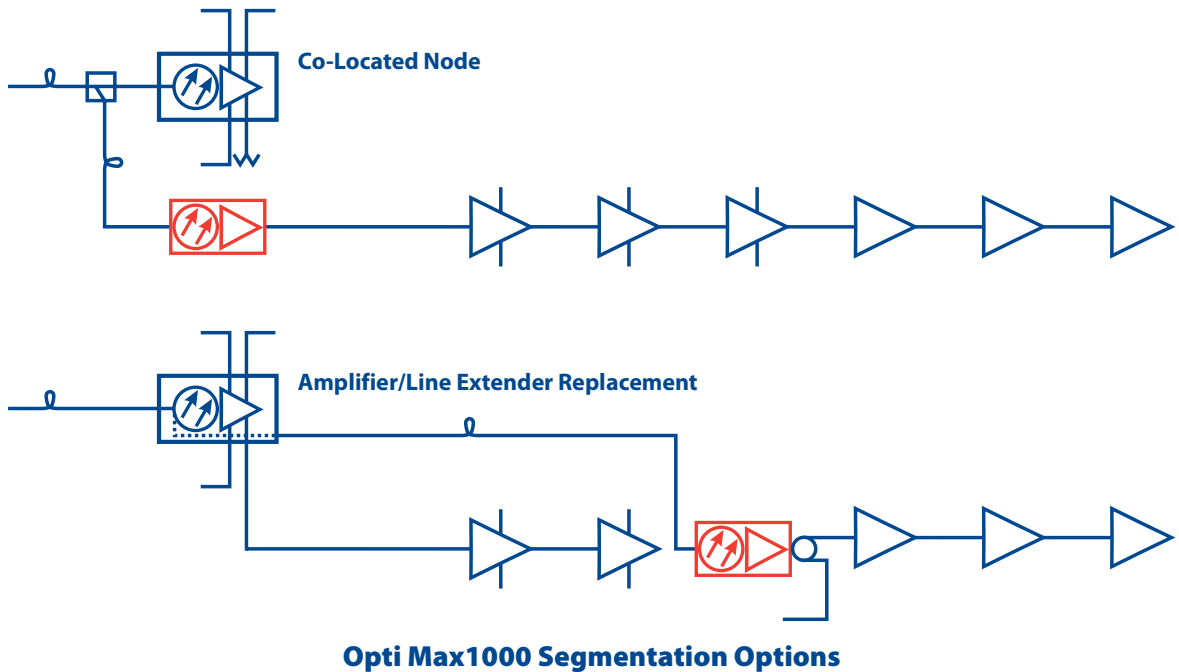

## WDM

WDM can be used within the Opti Max1000 to address system needs where existing fiber counts are low. For example, one fiber—as opposed to two—can be used to service the Opti Max1000. With the use of a 1310/1550nm WDM coupler installed in the Opti Max1000 fiber management tray, 1310nm forward path signals can be combined with 1550nm return path signals with just one fiber.

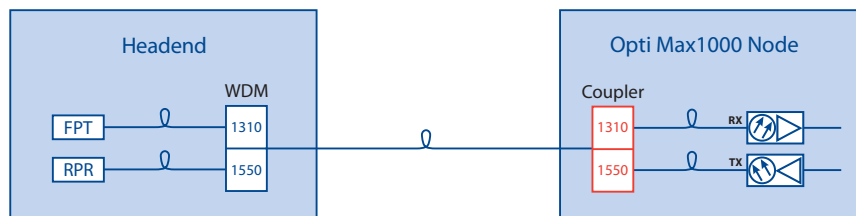

## Specifications

### General Specifications

Number of Active RF/AC Ports	1
DC Current Draw @ 24V, mA, max.	975
Power Dissipation, W, max.	29
Physical Dimensions (W x H x D), in (cm)	8.45 x 7.25 x 5.15 (21.5 x 18.4 x 13.4)
Weight, lbs (kg)	8 (3.6)
Operating Temperature Range, °C	-40 to 60

### Optical Specifications

Optical Input Wavelength, nm	1290 to 1600
Optical Input Range, dBm	-4 to 3
Return Transmitted Wavelength, nm	1310 ± 20 or 1550 ± 20
Optical Output Power, @ connector output, @ 23°C, dBm	3.0 ± 0.5
OMI, %, 10dBmV, single CW input, typ.	1310nm DFB TX: 13 1550nm DFB TX: 9

### RF Specifications

Operating Passband, MHz (Note 1)	Forward: 54 to 870, split dependent Return: 5 to 65, split dependent
Available Frequency Splits, MHz	42/54, 65/85
Maximum Recommended Output Level @ 870MHz (Note 2)	54.0
Forward Gain Slope, dB, with 7-TG862-10-WC installed	15.0 ± 1.0
Flatness @ Gain Slope	± 1.0
Return Loss, dB, min.	16.0
Nominal Return RF Port Input Level, dBmV/6MHz	10
Hum Modulation (Time Domain @ Rated Current), -dBc	65

Channel Link Performance (Note 3)	79 NTSC	60 PAL B/G	41 CENELEC
Reference Frequency, MHz	870/550/54	870/600/119/85	870/85
Analog Reference Output Level, dBmV	54/48.1/39	54/48.8/39.6/39	54/39
Composite Carrier to Noise Ratio, 4MHz/5MHz, 75 Ohm, dB	51	50	52
Composite Triple Beat, -dBc, typ./max.	68/65	68/65	59/56
Composite 2IM, -dBc, typ./max.	65/62	65/62	57/54
Cross Modulation, dB	61	61	54

### Performance Specifications

NPR Dynamic Range, NPR/dB Range (Note 4)	41/12
BER Dynamic Range, dB (Note 5)	40

#### Notes:

- Forward passband for the S2R-5N1 (no TX) version is 47 to 870MHz.
- The maximum recommended operating level of 54dBmV at 870MHz and 15dB tilt can be met with a minimum optical input level of -4dBm and 3.8% OMI.
- Using a C-COR CHP-FTX-06 transmitter, 0dBm input to the node, all fiber link, and 300MHz digital loading (79 NTSC) or 200MHz digital loading (PAL B/G) -6dBc to analog reference. The low reference frequency for the S2R-5N1 (no TX) version for 60 PAL B/G and 41 CENELEC channel loading is 47MHz.
- NPR Dynamic Range performance specifications over a 6dB link (15km fiber for 1310nm TX, 25km fiber for 1550nm TX) using 35MHz noise loading.
- BER dynamic range performance is measured with QPSK loading over a 6dB (15km fiber for 1310nm TX, 25km fiber for 1550nm TX) fiber link for a Bit Error Rate of  $10^{-6}$ .
- See specification document numbers 601279 (42/54MHz split) and 601288 (65/85MHz split) for more detailed specifications.

Specifications subject to change without notice

**Model Options**

				<b>1</b>	<b>2</b>	<b>3</b>		<b>4</b>	<b>5</b>	<b>6</b>		<b>7</b>	<b>8</b>	<b>9</b>
<b>S</b>	<b>2</b>	<b>R</b>	-	<b>5</b>	<b>x</b>	<b>1</b>	-	<b>x</b>	<b>1</b>	<b>x</b>	-	<b>x</b>	<b>x</b>	<b>x</b>

<b>1 Output Level</b>	
5	54dBmV

<b>2 Frequency Split</b>	
N	No split
A	42/54MHz
B	65/85MHz
	a
a) Must select "N" in #7 block, <b>Return Transmitter</b> .	

<b>3 Output Tilt</b>	
1	15dB

<b>4 Surge Protection</b>	
N	None
C	Crowbar surge protection

<b>5 Optical Connectors</b>	
1	SC/APC

<b>6 Wave Division Multiplexer</b>	
0	None
1	1310/1550nm wave division multiplexer (P/N WDM35SNS1B304545)
	a
a) Must select "Q" in #7 block, <b>Return Transmitter</b> .	

<b>7 Return Transmitter</b>	
N	None
P	2mW 1310nm DFB
Q	2mW 1550nm DFB
	a)
	b)
a) Must select "N" in #2 block, <b>Frequency Split</b> .	
b) Must select "0" in #6 block, <b>Wave Division Multiplexer</b> .	

<b>8 Power Supply</b>	
1	45 to 90VAC
2	110VAC
3	230VAC

<b>9 Housing Finish</b>	
0	Plain
1	Corrosion protected

**Americas Headquarters**

60 Decibel Road • State College • Pennsylvania • 16801 • USA  
 T: 1-814-238-2461 T: 1-800-233-2267 F: 1-814-238-4065

**EuroPacific Headquarters**

Transistorstraat 44-V • 1322 CG Almere • The Netherlands  
 T: 31-36-546 1111 F: 31-36-536 4255

Opti Max is a trademark and the C-COR logo is a registered trademark of C-COR Incorporated.  
 Copyright © 2006 C-COR Incorporated. All rights reserved.



www.c-cor.com